

# 3ND583 Microstepping Driver

## 1. Introduction

The 3ND583 is a high resolution 3-phase microstepping driver based on precision current control technology. It's suitable for driving 3-phase hybrid stepping motors from NEMA size 17 to 34. By using the advanced pure-sinusoidal current control technology, both the noise and vibration of the stepping motor have been greatly reduced, which makes the stepping motors offer servo-like performances. Compared to the 3MD560, it's lighter and smaller, and compared to most of the microstepping drivers in the market, both driver heating and motor heating have been reduced by 15-30%.

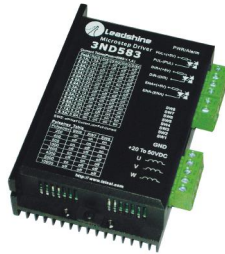

## 2. Features

- High performance, low noise and lost cost
- Low driver heating and low motor heating
- Supply voltage up to 50 VDC
- Output peak current up to 8.3A (RMS5.9A)
- Input signal TTL compatible
- Automatic idle-current reduction
- Suitable for 3-phase stepping motors, including 3 lead and 6 lead motors
- Optically isolated differential input signals,
- pulse frequency up to 300 KHz
- 8 selectable resolutions up to 10000 steps/rev
- DIP switch current setting with 16 different values
- PUL/DIR & CW/CCW modes optional
- Over-voltage, short-voltage, over-current, and short-circuit protections
- Small size for easy mounting

## 3. Applications

Suitable for a wide range of 3-phase stepping motors from NEMA size 17 to 34. It can be used in various kinds of machines, such as X-Y tables, labeling machines, laser cutters, engraving machines, and pick-place devices, and etc. They are extremely suitable for the applications desired with low noise, low vibration, high speed and high precision.

## 4. Specifications and Operating Environment

Electrical Specifications ( $T_j = 25^\circ\text{C}$ )

Parameters	3ND583			Unit
	Min	Typical	Max	
Output current	2.1	-	8.3(5.9 A RMS)	Amps
Supply voltage	20	36	50	VDC
Logic signal current	7	10	16	mA
Pulse input frequency	0	-	300	KHz
Isolation resistance	500			MΩ

Mechanical Specifications (unit=mm, 1 inch = 25.4 mm)

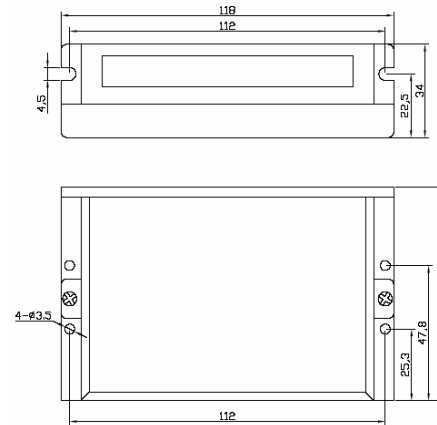

Figure 1: Mechanical specifications

## Operating Environment

Cooling	Natural cooling or forced cooling	
Operating Environment	Environment	Avoid dust, oil fog and corrosive gases
	Ambient Temperature	0°C — +50°C
	Operating Temperature	70°C
	Humidity	40 — 90%RH
	Vibration	5.9m/s <sup>2</sup> Max
Storage Temperature	-20°C — +125°C	
Weight	Approx. 280 gram (9.88 oz)	

## 5. Pin Assignment and Description

The 3ND583 has two connectors, connector P1 for control signals connections, and connector P2 for power and motor connections. The following tables are brief descriptions of the two connectors.

### Connector P1 Configurations

Pin Function	Details
PUL+(+5V)	<b>Pulse signal:</b> In single pulse (pulse/direction) mode, this input represents pulse signal, active at each rising edge or falling edge (set by inside jumper J1); 4-5V when PUL-HIGH, 0-0.5V when PUL-LOW. In double pulse mode (pulse/pulse) this input represents clockwise (CW) pulse. For reliable response, pulse width should be longer than 1.5μs. Series connect resistors for current-limiting when +12V or +24V used.
PUL-(PUL)	
DIR+(+5V)	<b>DIR signal:</b> In single-pulse mode, this signal has low/high voltage levels, representing two directions of motor rotation; in double-pulse mode (set by inside J1), this signal is counter-clock (CCW) pulse, active at low level. For reliable motion response, DIR signal should be ahead of PUL signal by 5μs at least. 4-5V when DIR-HIGH, 0-0.5V when DIR-LOW.
DIR-(DIR)	
ENA+(+5V)	<b>Enable signal:</b> This signal is used for enabling/disabling the driver. High level (NPN control signal, PNP and Differential control signals are on the contrary, namely Low level for enabling.) for enabling the driver and low level for disabling the driver. Usually left <b>UNCONNECTED (ENABLED)</b> .
ENA-(ENA)	

### Selecting CW/CCW or PUL/DIR Mode

There is a jumper J1 (including pin 1 to pin 9) inside the 3ND583 specifically for selecting pulse signal mode. Settings for the one-pulse mode (PUL/DIR) and for the double-pulse mode (CW/CCW) are shown in the following figure. Default mode out of factory is PUL/DIR mode and effective at rising edge.

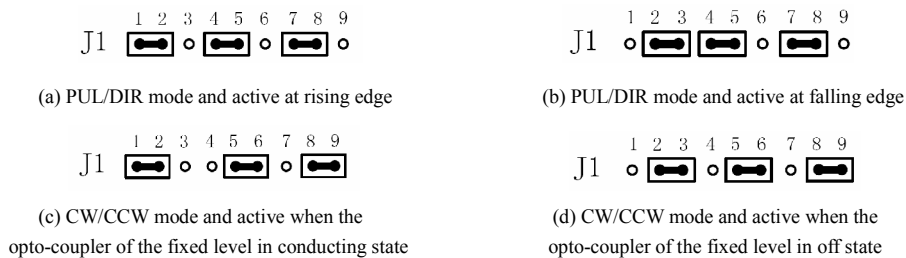

Figure 2: Control signal mode setting jumper

**Notes:** For (c), the user should move R137 (a 0Ω resistor) to R136 besides setting J1, and let R137 NC (open circuit).

## Connector P2 Configurations

Pin Function	Details
GND	DC power ground
VDC	DC power supply, +20VDC—+50VDC, Including voltage fluctuation and EMF voltage.
U	Motor phase U
V	Motor phase V
W	Motor phase W

**Remark:** Please note that motion direction is also related to motor-driver wiring matches. Exchanging the connections of two wires of a coil to the driver will reverse motor motion direction. (For example, reconnecting motor phase U to driver Phase V and motor phase V to driver phase U will reverse motor motion direction).

## 6. Output Current and Microstep Resolution Settings

### Setting Proper Output Current

For a given motor, higher driver current will make the motor output more torque, but at the same time causes more heating in the motor and driver. Therefore, output current is generally set to be such that the motor will not overheat for long time operation. Phase current rating supplied by motor manufacturer is important in selecting driver current, however the selection also depends on leads and connection.

### DIP Setting for Dynamic Current

The 3ND583 uses an 8-bit DIP switch to set motor dynamic current, standstill current and microstep resolution, as shown below:

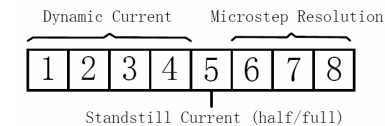

The first four bits (SW1, 2, 3, 4) of the DIP switch are used to set the dynamic current. Select a setting closest to your motor's required current.

Peak current (A)	RMS (A)	SW1	SW2	SW3	SW4
2.1	1.5	OFF	OFF	OFF	OFF
2.5	1.8	ON	OFF	OFF	OFF
2.9	2.1	OFF	ON	OFF	OFF

3.2	2.3	ON	ON	OFF	OFF
3.6	2.6	OFF	OFF	ON	OFF
4.0	2.9	ON	OFF	ON	OFF
4.5	3.2	OFF	ON	ON	OFF
4.9	3.5	ON	ON	ON	OFF
5.3	3.8	OFF	OFF	OFF	ON
5.7	4.1	ON	OFF	OFF	ON
6.2	4.4	OFF	ON	OFF	ON
6.4	4.6	ON	ON	OFF	ON
6.9	4.9	OFF	OFF	ON	ON
7.3	5.2	ON	OFF	ON	ON
7.7	5.5	OFF	ON	ON	ON
8.3	5.9	ON	ON	ON	ON

**Notes:** Due to motor inductance, the actual current in the coil may be smaller than the dynamic current setting, particularly under high speed condition.

#### DIP Setting for Standstill Current

SW5 is used for this purpose. OFF meaning that the standstill current is set to be half of the selected dynamic current, and ON meaning that standstill current is set to be the same as the selected dynamic current. The current automatically reduced to 60% of the selected dynamic current 0.5 second after the last pulse. Theoretically, this will reduce motor heating to 36% (due to  $P=I^2 \cdot R$ ) of the original value.

#### Microstep Resolution Setting

Microstep resolution is set by SW6, 7, 8 of the DIP switch as shown in the following table:

Steps/rev.	SW6	SW7	SW8
200	ON	ON	ON
400	OFF	ON	ON
500	ON	OFF	ON
1000	OFF	OFF	ON
2000	ON	ON	OFF
4000	OFF	ON	OFF
5000	ON	OFF	OFF
10000	OFF	OFF	OFF

## 7. Typical Connection

A complete stepping system should include stepping motor, stepping driver, power supply and controller (pulse generator). A typical connection is shown in the Figure 3.

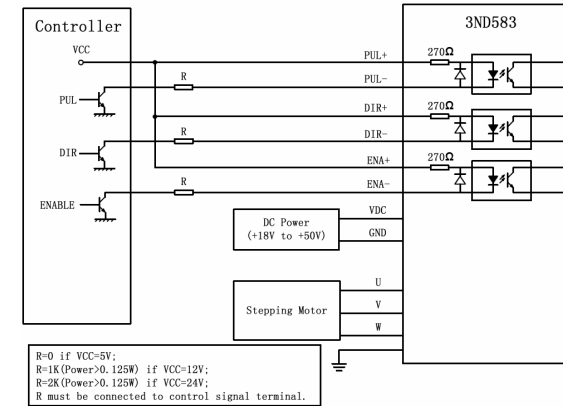

Figure 3: Typical connection